

MIG-T Tube Preamp for Hammond T-Series Organs

By Carsten Meyer & Tonewheel Tubeworks, cm@tonewheel.de

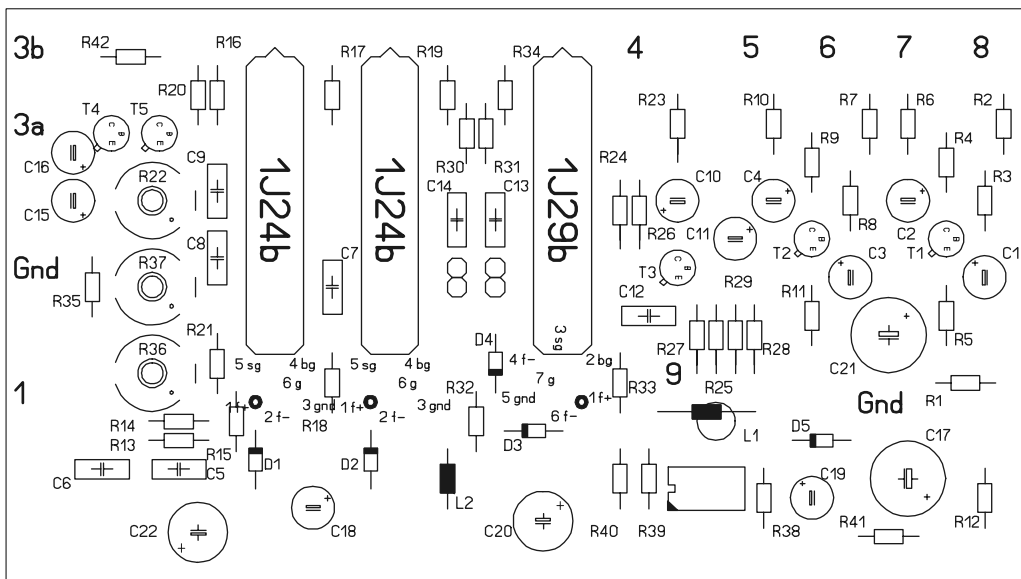

Board layout of MIG-T printed circuit board

Want that sweet tube sound for your transistorized organ? Install a real tube amplifier in your T-series spinet organ!

But wait... don't those tubes require a lethal high anode voltage and a big transformer for heating? True for most, but not for mine. I found some miniature tubes that work perfectly with the organ's 24V power supply, they need only a few milliamps for heating. See the diagram on next page: A tube output stage replaces Hammond's transistor preamp output stage, and two overdrive stages add the "growl" if needed.

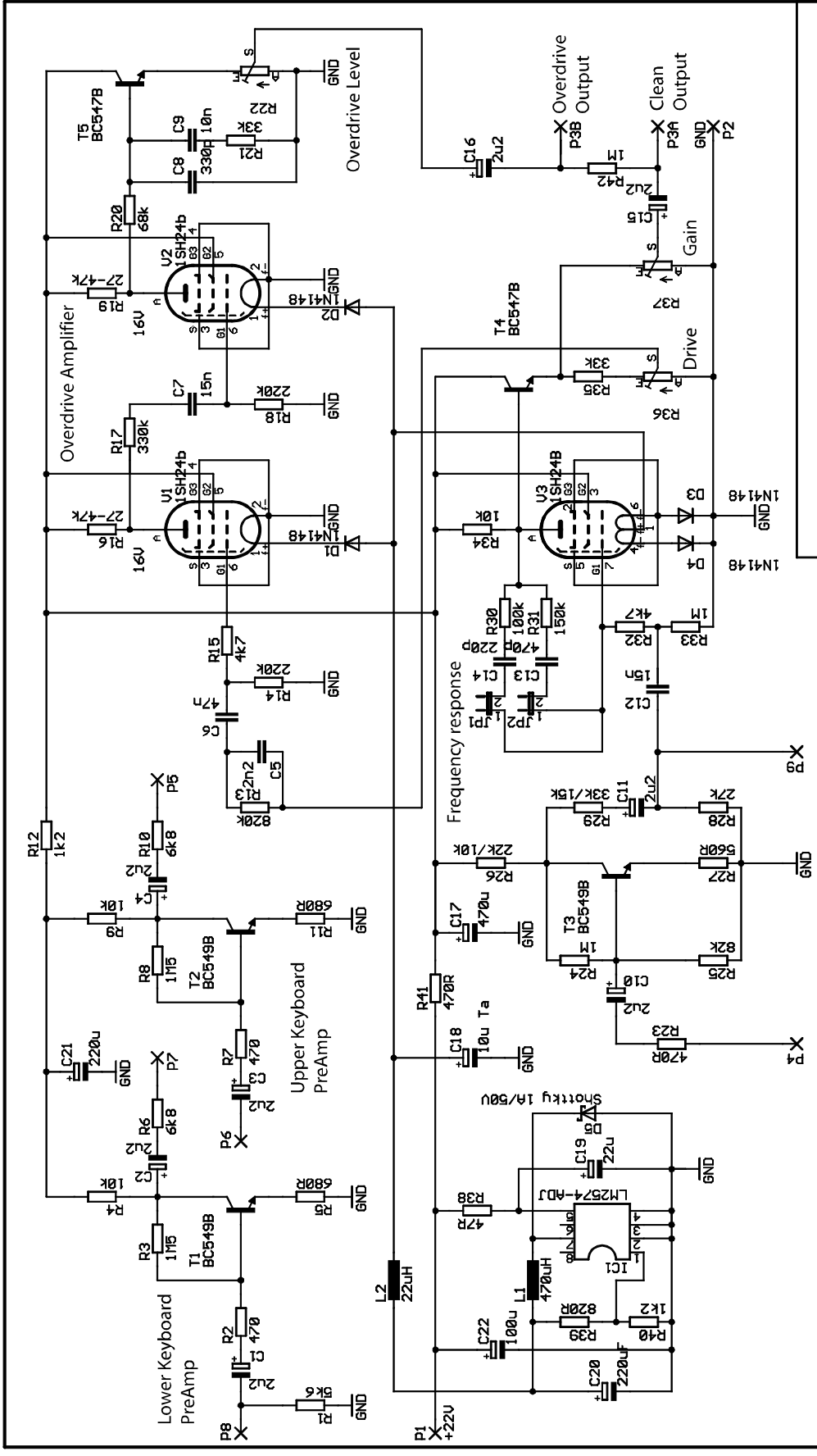

Instructions on www.tonewheel.de/hammond/
 Please use +Ub (P1) from vibrato board (red wire) instead of yellow wire!
 Set Jumpers JP1 and JP2 to personal taste.

TITLE: migtubepreamp

Document Number:

Date: 23.09.2003 20:59:32

Sheet: 1/1

REV:

Let the Russians do the work!

Remember russian pilot Victor Belenko who defected to Japan in his **MIG-25 Foxbat fighter** back in 1976? U.S. military officials were stunned when they examined what they thought was the most advanced fighter jet in the world. The Russians, it turned out, were still using **old-fashioned vacuum tubes** instead of state-of-the-art transistors and computer chips. For all their vaunted military reputation, the Soviets seemed incredibly backward. Eventually though, it dawned on the Americans that the Soviets had figured out the old tubes would be less vulnerable to the electro-magnetic pulse of a nuclear blast than some newer components. The MIG-25 fighter was equipped with thousands of miniature vacuum tubes, and most of them are still available, since the russians literally made millions of them for military stock.

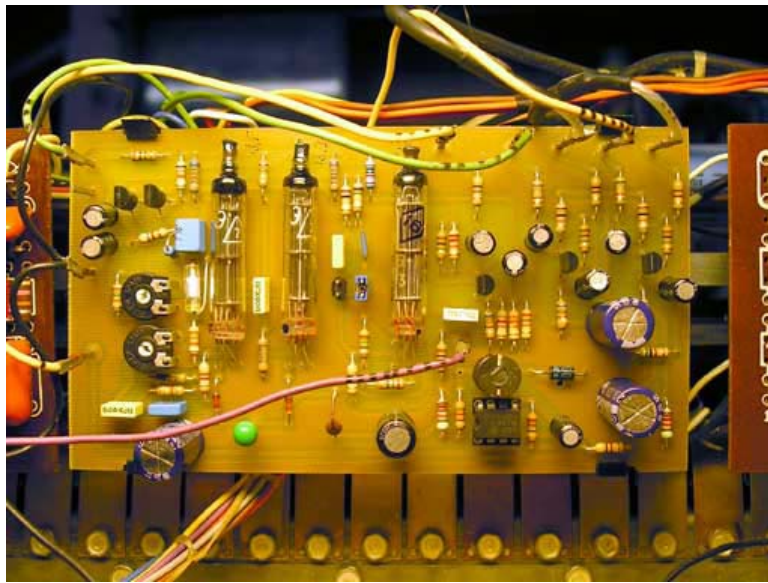

Upper picture above shows the pre-productional prototype of the **MIG-T** preamp. The tube in the middle of the PCB (type 1SH29b or 1J29b) is the **preamp output stage**, the two tubes to the left (type 1SH24b or 1J24b) work as the **additional overdrive stage**. The IC to the right is a LM2574ADJ "Simple Switcher", a high-efficiency switching power supply circuit which produces the 1,2V DC for heating. The transistorized preamp stages (upper right side) are fitted with **low-noise transistors** and straight frequency response. The two transistors to the left work as emitter-follower to adapt the tubes' high output impedance to the output. Bias is chosen to drive the preamp output tube **slightly in distortion**, which is of very "sweet" type and adds a nice warm tone. The **additional overdrive stage** adds a compression and a soft symmetrical clipping which resembles the sound of an overdriven Leslie 122 amp, all with that vintage "thump". **Overdrive gain** and output volume is setttable by the trimpots on the left. Two jumpers between the tube stages define the amount of key click by different high frequency responses. You may use either the clean output or the overdriven output (choose by a obsolete tab switch, by example).

The MIG-T preamp **simply rocks** - download the MIG-T tube preamp MP3 sound example at <http://www.tonewheel.de/hammond/t-mod-skill4.htm> (clean and overdriven, played on a plain T-500 with all my published modifications, solely through internal leslie unit and internal speakers). I apologize for the quality of the performance - I'm a technician, not a skilled player!

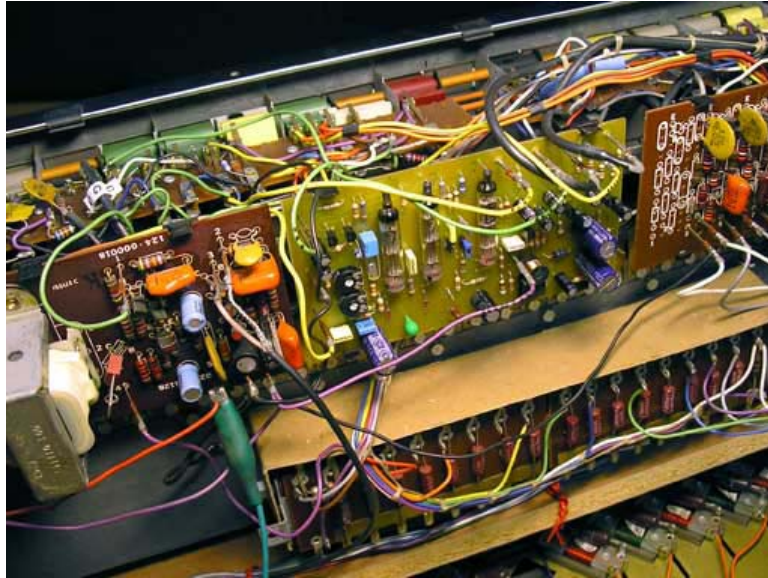

MIG-T Preamp installed in a T-562

Installation instructions

The **MIG-T** comes ready built and is pretty easy to install. Please read Skill 1 to 3 on <http://www.tonewheel.de/hammond/t-modifications.htm> to disassemble the organ and to remove the original transistor preamp board 124-000014. Write down the wire numbers and tag the wires. The MIG-T pinning (see MIG-T circuit schematics - actual circuit might be changed without notice) has the same order and numbering scheme as the Hammond board, with two exemptions: First, power supply is routed from the red +24V wire of the adjacent **vibrato preamp board** (left board on pictures, see green alligator clip on right picture). The filtered +21V supply (former yellow wire to pin P1) is not capable of the heater current required for the tubes. Cut the yellow wire or tug it away. Second, it has two outputs (upper marked "3b" for overdrive, lower "3a" for clean tube sound). You may route both to an on /off toggle switch and back to the green pin "3" wire to change to overdriven sound by simply flipping a switch. I used the "Reiteration" tab for this purpose. Remove the existing wires from the switch and connect those which are normally connected in "Off" position. Who really needs reiteration on percussion voices?

Adjustment

The trimpots adjust overdrive output level (upper), clean output level (mid) and drive gain (lower). First set clean output level R37 to a non-distorting output with swell pedal floored. Adjust overdrive gain R36 to personal taste and a warm, not too harsh sound. Adjust R22 to same overdrive output volume as clean output. The two jumpers set the frequency response. For a non-recalibrated tone generator, you have to install both, leaving one or both open yields more treble and more key click. Please remind: If you want that smooth, rumbling Hammond growl, you definitely have to recalibrate the generator (see my web page for instructions).

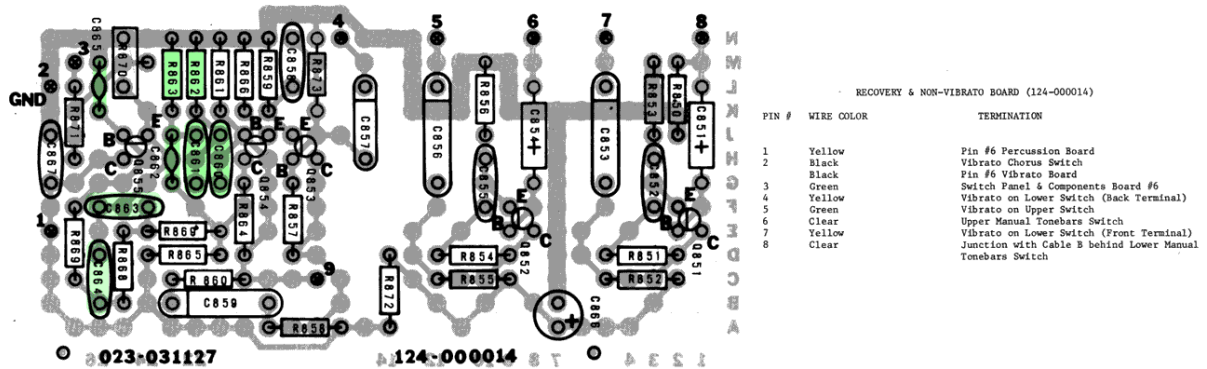
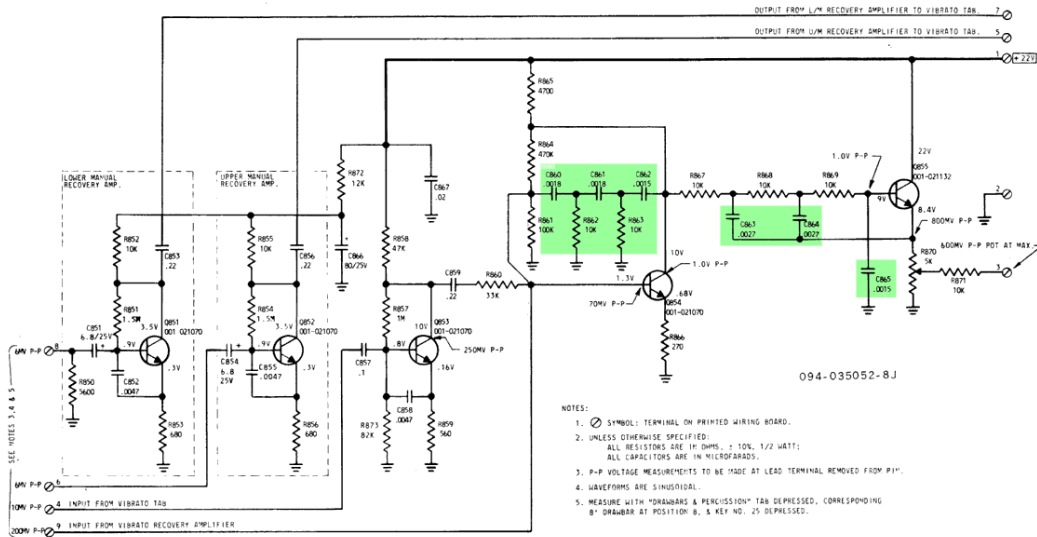

This is the original Hammond recovery transistor preamp board 124-000014, which is completely replaced by the MIG-T Preamp.

For support and complete modifying instructions, visit our webpage

www.tonewheel.de/hammond/